Title	Mathematical modelling as problem solving for children in the Singapore mathematics classrooms
Author(s)	Chan Chun Ming Eric
Source	<i>Journal of Science and Mathematics Education in Southeast Asia</i> , 32(1), 36-61

This document may be used for private study or research purpose only. This document or any part of it may not be duplicated and/or distributed without permission of the copyright owner.

The Singapore Copyright Act applies to the use of this document.

Original source of publication

at http://www.recsam.edu.my/R&D_Journals/YEAR2009/june2009vol1/mathmodelling%2836-61%29.pdf

The final publication is available at www.recsam.edu.my

Mathematical Modelling as Problem Solving for Children in the Singapore Mathematics Classrooms

Chan Chun Ming Eric

National Institute of Education, Nanyang Technological University,
Singapore

The newly revised mathematics curriculum in Singapore has recently factored Applications and Modelling to be part of the teaching and learning of mathematics. Its implication is that even children should now be involved in works of mathematical modelling. However, to be able to implement modelling activities in the primary mathematics classroom, it is at the outset needful for teachers to have an understanding of what it is, how it is different from conventional pedagogies, and what the learning outcomes look like. Since the goal of the Singapore mathematics curriculum is problem solving, I discuss mathematical modelling as problem solving and examine the mathematical reasoning of two groups of high-ability Primary 6 students in their engagement of a model-eliciting task based on a classroom research. Comparisons of the two groups within the modelling stages show that primary school students were able to reason mathematically towards constructing models.

Key words: Mathematical modeling; Problem solving; New mathematics curriculum

Introduction

The mathematics education landscape continues to undergo rapid change. Education reform movements are increasingly advocating pedagogies for teaching and learning with understanding alongside the development of students' problem-solving and critical thinking skills. As well, the rationale for change has been tied to preparing students for a knowledge-based workforce possessing competencies and skills beyond school. Reformed pedagogies demand that students take ownership of their learning and construct knowledge as they interact with the dynamic environment.

In the field of mathematics education in Singapore, there have been revisions made to the mathematics curriculum to reflect changes that align with international reform movements. The Singapore Mathematics Curriculum Framework (SMCF) has mathematical problem solving as its central goal since the early 1990s. The framework asserts that to develop students to become good mathematical problem solvers, it is dependent on five inter-related components, namely, the development of skills, concepts, attitudes, metacognition, and processes (MOE, 2001). As of 2007, the Ministry of Education (MOE) has included mathematical processes such as *mathematical reasoning, communication and making connections*, as well as *applications and modelling* into the teaching and learning of mathematics (MOE, 2007). The deliberate inclusion of the new mathematical processes is seen as a significant step towards making problem-solving more relevant. Not that *applications and modelling* were not taught in schools, they were mainly subsumed under the topic Differential Equations in pre-university mathematics. The new curriculum now states that *applications and modelling* “should be part of the learning for all levels” and defines it as “the process of formulating and improving a mathematical model to represent and solve real-world problems” and that “students should learn to use a variety of representations of data, and to select and apply appropriate mathematical methods and tools in solving real-world problems” (MOE, 2007, p.14). These new inclusions are by no means a minor extension to the curriculum. To promote mathematical processes such as these will require alternative pedagogies and assessments that sharply contrast with conventional ones. At the same time, teachers’, students’ and stakeholders’ beliefs have to be addressed continually towards embracing the newer pedagogies. For educators and teacher practitioners, it thus begs the questions: In the mathematics classroom, what do the manifestations of students’ learning look like if they are to be different from conventional practices? What mathematics is used or mathematical thinking is manifested when students work on modelling activities? For unless educators and teachers see what entails as learning outcomes in reformed practices and value them as essential, it would be difficult to move away from classroom practices that are predominantly teacher-centered.

In Singapore, no known research on mathematical modelling has been carried out with children except the one that I am currently conducting. Just as it has been found from research overseas that children were capable of

developing their own models and sense-making systems in complex problem situations (English, 2006; English & Watters, 2005; Lehrer & Schauble, 2000), my local classroom-based research have reported that primary 6 students' displayed abilities in identifying goals and variables, interpreting problem situation, interrogating data, inquiring and self-monitoring, improve conceptualisations, and extending their thinking during mathematical modelling (Chan, 2008). Research, however, in this field of mathematical modelling involving children have been few (Lehrer & Schauble, 2003) suggesting that more could be done to add to this domain of knowledge in mathematical modelling and problem solving.

The purpose of this paper is to discuss mathematical modelling as problem solving and examine the mathematical reasoning and models of two groups of Primary 6 students in their engagement with a model-eliciting task based on a classroom research. Some implications and challenges are also discussed with respect to implementing modelling activities in the Singapore mathematics curriculum.

Mathematical Modelling as Mathematical Problem Solving

Mathematical modelling has recently been advocated to be the new direction for research in mathematical problem-solving (Lesh & Zawojewski, 2007) and regarded as the most significant goals of mathematics education (Lesh & Sriraman, 2005). In the light of the issues raised in mathematical problem-solving research were concerns about students' preparedness in solving problems in a world that is becoming more complex (English, 2003; Mousoulides, Sriraman, & Christou, 2007) as well as the need for students to function in unfamiliar situations towards eliciting important problem-solving abilities and behaviours (Lesh & Doerr, 2003). These deliberations demand a different viewpoint of problem solving where problem solving entails a number of trial procedures between givens to goals that involve refining and improving one's solutions rather than working through a problem from givens to goals ordered by a set of definitive procedures (Lesh & Doerr, 2003).

Traditionally, mathematical modelling tends to be associated with higher school pure and applied mathematics (geometry, algebra, calculus, etc.) to solve real-world problems. Even in the primary school setting, the modelling has been about representing structured problems with concrete materials

and abstract operational rules (English, 2003). Although they serve important purposes, the traditional sense of modelling has been claimed to be inflexible for want of trying to fit intact models into dynamic problematic situations (Yoon & Thompson, 2007). Another limitation has been attributed to the direct mapping between the structure of the problem situation and the structure of a symbolic expression that leads to only one way of interpreting the problem which do not address adequately the mathematical knowledge, processes, representational fluency, and social skills needed for the 21st century (English, 2003). The current view of mathematical modelling stemming from a models-and-modelling perspective (Lesh & Zawojewski, 2007) sees students' modelling process as going through multiple cycles in developing a mathematical model for a given problematic situation. The cycles of model construction, evaluation, and revision are valued in the light of befitting the professional practices of mathematicians and scientists as well as those of other disciplines such as biotechnology and aeronautical engineering (Lesh & Doerr, 2003). Such cycles convey a more realistic process of problem solving that depict what scientists and engineers do in generating models and conceptual tools towards problem resolution.

A modelling perspective to mathematical problem solving focuses on the students' representational fluency through the flexible use of mathematical ideas where the students have to make mathematical descriptions of the problem context and data. When students paraphrase, explain, draw diagrams, categorise, find relationships, dimensionalise, quantify, or make predictions, they are generally developing their conceptual systems or models through the mathematizing. As they work with the rich contextual data, they would need to surface and communicate their mathematical ideas to clarify their thoughts and weigh the validity of their ideas. In other words, when students engage in model-eliciting activities, their "(internal) conceptual systems are continually being projected into the (external) world" (Lesh & Doerr, 2003, p. 11) thus making visible their sense-making systems of mathematical reasoning in the form of a variety of representational media such as spoken language, written symbols, graphs, diagrams, and experience-based metaphors. It is asserted that when students go through such cycles of expressing, testing, and revising, the full process of modelling as problem solving is seen as the process of "making practice mathematical" (Lesh & Zawojewski, 2007, p. 785) where mathematical practice is learned through experience of problem solving as contrasted with

traditional notions of making mathematics practical. As interpretive cycles take place within the modelling process, multiple mathematical interpretations of students are elicited within each modelling stage. From this perspective, the modelling process is a non-trivial and thought-revealing problem-solving process.

A Conceptual Framework

The present study that I am pursuing is part of a larger study in investigating primary 6 students' mathematical modelling process. This study adopts a conceptual framework that integrates the modelling approach into a problem-based learning (PBL) instructional setting. The PBL setting is to highlight the importance of the interaction between three essential tenets characteristic of problem-base learning; the unstructured task, the teacher-scaffolding, and the student collaboration. A model-eliciting task in many ways befit the characteristics of the type of tasks suitable for use in PBL settings; complex, authentic, able to trigger critical and metacognitive thinking, requires iterative processes, and decision-making moments (Tan, 2003; Uden & Beaumont, 2006). The task is also specifically designed based on principles that are aligned with reformed classroom practices that include a modelling slant. The model-eliciting task would provide the context for argumentation and collaboration, and the teacher functions as a facilitative coach to provide scaffolding at certain junctures of the modelling process. Student-student interaction in relation to the task as well as the teacher-student interaction in relation to the task would generate discussion around problem interpretation, variables, and strategies towards solving the problem. The pupils' cognitive processing is manifested through the discourse as mathematical modelling behaviours of mathematical interpretations found within iterative modelling stages of *Description*, *Manipulation*, *Prediction*, and *Optimisation*. In this paper, *Description* refers to attempts at understanding the problem to simplifying it which includes behaviours of drawing inferences from text, diagrams, formulas or whatever given data to make sense of the task details. It also entails students making assumptions from personal knowledge to simplify the problem as fitting the contextual parameters. *Manipulation* refers to behaviours of establishing relationships between variables, mathematical concepts, and task details through constructing hypotheses, critically examining contextual information, retrieving or organising information, mathematizing, or using

strategies towards developing a mathematical model. *Prediction* refers to the scrutinising of the models that the students have conceived as they analyse the designs or solutions towards ensuring that they fit the parameters given or established. *Optimisation* refers to making improvements to or extending the models or comparing or suggesting the effects the models might have if other conditions are imposed to justify its optimised state.

During mathematical modelling, the conceptual interpretations that students develop are conceptual systems or models which are representations of elements of ideas, concepts, constructs, or relationships made explicit in representational media such as text, diagrams, metaphors, or verbal explanations through the connections and operationalisation of these elements. They are purposeful descriptions or explanations about mathematical components (e.g. quantities, shapes, locations, etc.) and their relationships to represent meaningful situations. The models can be evidenced through the ways the pupils derive at or conceive for example, a graph, a table, a pattern, a benchmark, or a set of mathematical operations. The models are constructed as pupils go through multiple cycles of expressing, testing and revising during their interpretation of the problem task and their interaction with one another. A different model represents a shift in thinking in the ways they work towards problem resolution.

Methodology

The main study employed a mixed-method design where both quantitative and qualitative data were collected and analysed. The study was designed over two phases where Primary 6 students were involved in five different types of model-eliciting tasks. This paper will cover the learning outcomes of the students from the Phase One study where they were engaged in the model-electing task known as the Biggest Box Problem. Each session lasted close to an hour.

The study took place in two neighbourhood schools where two classes of Primary 6 students each and their respective mathematics teachers were involved. Prior to the study, both teachers and students had no experience in model-eliciting activities. The mathematics classroom instruction had mainly been the teacher-expository type.

The Model-Eliciting Task - The Biggest Box Problem

The model-eliciting task was designed based on design principles of reformed classroom instruction and from a modelling perspective (De Lange, 2001; Lesh, Cramer, Doerr, Post, & Zawojewski, 2003). The Biggest Box problem used in the discussion in this paper (Figure 1) was contextualised to make the problem solving take place in a natural setting where the students were supplied with 50cm by 50cm vanguard sheets, scissors, tapes, markers, rulers, and calculators, and they had to make the biggest box they could.

Your team is participating in a math project competition where you will need to present your findings in two days' time. In the competition, each team has been given only two square sheets made of vanguard. The team can decide if they want to use one vanguard sheet for trial. The team is supposed to make the biggest box (volume) using only ONE vanguard sheet. How would your team plan to solve the problem of making the biggest box? Show in detail how you reach a solution to convince the judge.

Figure 1. The biggest box problem.

To manage the construction task, the students had to work in small collaborative groups and present their findings to the teacher and me who were supposed to be the judges. It was a novel task because they had not encountered such a problem before and the task sheet did not provide any printed numerical figures to begin with, quite unlike the structured word problems they were so used to doing. However, embedded within the task were mathematical ideas related to measuring, dimensionalising, nets, comparing, and optimising. Students were expected to cut out four squares from the corners of the square vanguard sheet (see Figure 2) and then fold the remaining four sides to obtain an open box with a square base. In order to find the biggest volume, they needed to relate how the size (length) of the cut-outs would affect the volume of the box. It was not expected that the students should get the exact maximised volume since they did not know calculus but what was important in this instance was how they would arrive at a volume that they could justify as being the largest and be satisfied and convinced with their arguments. The task would have served its purpose if it had been able to elicit multiple conceptual interpretations (models) through

the way the students situate the problem, make sense of variable relationships, represent the data, analyse their model solutions, and describe how they optimise their solutions to depict their mathematical thinking.

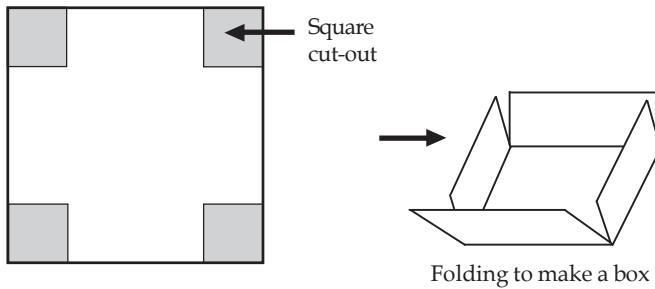

Figure 2. The making of a box.

Preparation Procedures for Teacher-Facilitators

The mathematics teachers of the respective classes participated as teacher-facilitators. Prior to the modelling session, the teacher-facilitators were brought through a facilitation training session with the author. They were introduced to the model-eliciting task and were guided through the facilitation aspects via the use of scaffolding prompts for eliciting, supporting and extending students' responses, a scaffolding framework adapted from Frivillig (2001). The teacher-facilitators had to conduct a word problem-solving session in the class to get the students acquainted with thinking-aloud and helping behaviours while working in small collaborative groups. They were also instructed to periodically spend short dedicated time with each group to find out about each group's progress and offer scaffolding whenever appropriate during the actual modelling session.

Participants and Groupings

146 Primary 6 students from two primary schools took part in Phase One of the study. 42 students from Class A and 40 students from Class B from a school in the North Zone and 32 students each from Class A and Class B from a school in the East Zone were involved. The students in Class A of both schools were considered higher-ability students while the students in Class B of both schools were mixed-ability students.

The students were assigned into small groups of fours and fives. The two main criteria for the assignment of group members were that each member should feel comfortable enough with their friends to negotiate and communicate their ideas, and that the groups should be heterogeneous in terms of mathematics ability. This prevented having a group with all members who were very good or weak in mathematics. One group of five students was selected from each class by the teacher as the target group for the video-recording. The selection was based on the teachers' knowledge that the students were the more vocal ones in the class who could provide relevant data suited for the purpose of the study. The other non-target groups were also involved in the problem solving but they were not video recorded.

Data Collection and Analysis

Data were collected through video-recordings of the target groups of students during the modelling sessions. Other data sources included my field notes and the students' written products, journals, and artifacts that were collected at the end of the session to serve as triangulation materials to the recordings.

Video data were transcribed and the students' protocols were coded based on a problem-solving coding scheme developed for this study and used as a basis for episode parsing into modelling episodes synonymous to the modelling stages: *Description*, *Manipulation*, *Prediction*, and *Optimisation*. The protocol analysis method was used to provide the descriptive interpretation of the students' construction of their conceptual models for this task. The protocol analysis method assumed that the problem-solving process would have been task-analysed where the elements and operators were already defined a priori so as to be able to identify "what vocabulary in the protocols is used to refer to these elements and operators" (Chi, 1997, p. 287). The predetermining of the elements and operations had been factored during the design of the model-eliciting task, and this coupled with the matching of the problem-solving codes thereby enabled a more accurate interpretation of the protocols. To enhance the credibility of the coding, the protocols were also reviewed several times by two Primary school teachers and me towards the convergence of meanings of the protocols and revising of the coding scheme as well.

Results

In this paper, only the qualitative findings based on two target groups of students' mathematical reasoning and construction of conceptual interpretations within the modelling stages is presented. It must be noted that the two groups were students from the high-ability classes of the two schools. It was unfortunate that the recordings for both the mixed-ability groups ran into problems. One was due to equipment failure, and the other was because the other non-target groups were too near the target group, hence the noise generated by the other groups overwhelmed the conversations of the target group. This would be considered as a limitation to the presentation of the findings in this paper.

The target groups are labeled as Group HA1 and Group HA2. Both groups comprised five students and are labeled as S1, S2, S3, S4 and S5. The teacher-facilitator is labeled T.

Modelling Stage: Description

HA1

Task and needs analysis. The group commenced by breaking down task information. They asked about what their goals were, and they evaluated the task:

S1: How to?

S5: My first thought is 'How do we make this kind of thing?'

Initial deliberations centered on the difficulties facing them. They were momentarily stuck but proceeded to discuss what they knew and did not know about the problem.

S5: (Did not know) The length and breadth of the vanguard sheet.

S4: We do not know the shape of the box.

S2: Must find the length and breadth of the vanguard sheet, and what shape of the box should be, whether it is rectangle or square.

As they tried to make sense of the problem, it was observed that they began to surface the mathematical components such as "box", "shape", "length", and "breadth". They surfaced ideas about dimensions and measurements. Following that, they took action by measuring the length and breadth of the vanguard sheet towards finding its area.

HA2

Qualitative geometrical considerations. The group focused on conceptualising what the shape of the box could be. The deliberation about the shape of the box was probably enhanced because the teacher-facilitator was present at that point and she questioned “*What makes you so sure that it must be a square?*” The students thus raised several possibilities:

S3: ...there are pentagon-sized boxes.

S3: It need not be a square base.

S4: What if we try rectangle?

Their initial considerations did not lead them to an answer as to how the different shapes a box could take would affect the volume. But what they knew was that by considering more shape options, they would “...end up with more possibilities” and “endless possibilities”. The students thus knew that they had many variables relationships to consider. At another juncture of the modelling process, the group returned to the *Description* stage. They felt that they should consider other possibilities.

S4: Can we try triangle base? Then it is not a box?

S2: There's cylinder base.

S1: It is a box ok.

S2 even suggested how the volume could be measured for a “cylinder-based” box:

S2: You measure the below, the base first, then you times the height. But how do we make a cylinder out of this?

S3: Just roll the thing (vanguard sheet) and tape it.

Later, the group iterated from another round of exploring to once again discuss if the shape of the box could be a prism or a pyramid. Each time, they reasoned that the variable relationships were too many and too complicated to be considered, so these potential attempts to actually explore the other shape options did not materialise.

The two groups used different approaches. HA1 was more methodical by way of doing a task and needs analysis. They talked about their goals, and then discussed what they knew or not know about the problem. Through it, they simplified the task details by delineating the mathematics constituents essential for solving the problem.

HA2 brainstormed about what possibly could the shape of the box be. Although they did not explicitly verbalise specific mathematics components (length, breadth, area) at the beginning of their modelling endeavour, they seemed troubled as they could not determine which shape would give them the biggest volume. They periodically returned to ask about other possible shape options for designing the box which perhaps could have given them even bigger volumes. HA1 on the other hand, did not quite deliberate about other shapes because they had quickly thought of the net of the box and they zeroed in and used the idea to construct the box.

Modelling Stage: Manipulation

HA1

Geometrical Manipulation. The group was quick to determine how to get a box from the vanguard sheet.

S3: *Net. You know, volume and net?*

S4: *Six sides.*

S1: *You cut six sides? We'll need only five faces. The box don't need to cover up.*

What followed was S5's gesturing to demonstrate how the vanguard sheet should be cut as she conjectured: "...this side you cut right? Then later this side you fold. You cut as small as possible. The shorter you cut, the shorter the box is". S5 was actually reasoning how the size of the cut-outs would affect the height of the box when folded as presented in Figure 2.

Misconception. A student's misconception was observed when she could not relate the idea of the nets (focusing on the cut-outs and the folding) with the volume of the box to be constructed:

S1: *No matter which way you make it, forever it'll be the same volume. I mean like you cut off this part. Whatever you cut is the same. It's the same volume. It's the same amount of paper. You can't make it bigger or smaller.*

But later, she on her own realised her misconception:

S1: *The shape of the cuboid does not affect the volume. Eh...No.*

In fact, S1 was able to make a conjecture as observed in the next segment.

Conjecturing. It was observed that S1 and S5 got into some arguments over their conjectures.

S1: *We can cut 0.1cm. We can cut 0.1 then we get the biggest volume.*

S5: *0.1? You got to be joking. How to get the biggest volume? You mean you can cut out this much? We're supposed to convince the judge. We're going to present a box with 0.1 in height? Is it like a box? You go and cut! No. It won't be 0.1 in height.*

S1: *Yes it is. It will.*

S5: *Ridiculous!*

S1 proposed cutting out squares of 0.1 cm by 0.1 cm from the four corners of the vanguard sheet. Her thinking was to leave a big square-based area to multiply with the height of 0.1 cm to get a big volume. This made mathematical sense and was quite a strategic move. S5 however was more pragmatic. She could not see the possibility of how a square of 0.1 cm by 0.1 cm could be physically cut, thus she challenged S1 to show or prove to her. Both S1 and S5 had presented plausible arguments; one mathematically, the other practically.

Listing Systematically Towards Generalisation. As the group trialled with different lengths for the cut-outs, their initial generalisation was that "...we make the bigger the box, the height is higher...". They found out that as they increased the height, the volume became larger. But as they trialled further, they became uncertain about the generalisation. This was because the last volume that they had obtained went up to 9486 cm^3 before it decreased to 8652 cm^3 . (The figures the students arrived at were based on manipulations with 50.8 cm as the length of the vanguard sheet instead of 50 cm due to human errors in the physical measurements done).

S3: *8652...how come we're getting lesser? Hey you get lesser.*

They then proposed ways to make their exploration more systematic:

S2: *Wait. Let's try again. We'll try between 10 and 20 cm.*

S4: *Now lets' do a guess-and-check.*

S2: *Why don't we make a table like 10cm, 11cm, 12cm, 13cm, 14cm?*

HA2

Geometrical Manipulation. Although the group had deliberated about what shape the box should take (in the *Description* stage), the group had mainly focused their discussion on using squares as faces for the box as that was

deemed most manageable.

S4: 2500 divide by 5...Now we're finding area, right? So, 5 parts. 5 pieces because the cover we don't need. So the area is 500. One side is 500.

S4's thinking was that there should be five faces to make a box without the lid. If the area of the vanguard sheet was to be 2500 cm^2 , then by dividing by five, each face should be 500 cm^2 .

Misconnection and Misconception. The reasoning provided by S4 appeared to make sense. It provided the evidence that S4 was able to conceive the net of a square box and how each face should have the same area. However, there was a misconnection because S4 did not perceive that it could not be done. A square vanguard sheet with area 2500 cm^2 could not be divided equally into five squares measuring 500 cm^2 each. This was discovered by a team member when they tried to actually perform the cutting:

S2: No, cannot because we're cutting some away.

In another episode S5 was trying to picture a box with dimensions 50cm by 50cm by 50cm. This was quickly retorted by a member who said:

S4: No. Cannot be 50, 50, 50. Then the height is zero. 50 times 50 then the height is zero.

Recognition of a Pattern through Trialling and Listing. The group was involved in trialling using different dimensions for the lengths of the cut-outs as they worked towards getting the maximum volume respective volumes of the box. S2 began to sense a certain pattern when he blurted out:

S2: So every time the length (of the square cut-out) decrease by 2, the height will increase by what?"

S2 answered the question himself "Increase by one" when his teammates did not get what he was saying. Although the word "increase" and "decrease" used by S2 were not the best terms to use in this context, what he meant was that every time two lengths of the square cut-outs were removed from the corners of the vanguard sheet, one length of the square cut-out corresponded to height of the box. This was evidenced from the transcript which recorded their listings such as 30, 30, 10; 48, 48, 1; 46, 46, 2. From working out the combinations, the group found $34 \times 34 \times 8$ to give the biggest volume.

It was evident that both groups used and worked on the ideas of nets in order to construct a box. Both groups explored relationships between variables – nets, faces, lengths, breadths, heights, areas and volumes. Both groups struggled with making connections among the variables and both groups also showed initial misconceptions. It was interesting to note the misconceptions and misconnections that surfaced as the students wrestled with their mathematical ideas and equally heartening to see how they resolved the problematic areas among themselves. Their explorations within the *Manipulation* stage gradually led them to make important conjectures and generalisations. Strategies such as systematic listing were evident as well when the groups tried to narrow the range for the dimensions in their explorations.

Several interesting incidents occurred that showed how the groups dealt with misconceptions and different viewpoints. For example, the discourse between S1 and S5 from HA1 showed that both had presented legitimate arguments about their conjectures. One argument centred on a mathematically workable solution while the other on the practicality of the solution. Likewise, the other interesting aspect was the tension observed in HA2 in reconciling the area of 2500cm^2 as five square faces of 500cm^2 each.

It was during the *Manipulation* stage that the students' emerging models became more evident. Both the groups were able to construct (as already pre-determined through the design of the task) two emerging models. The groups established a conceptual model by looking at the design of the box through the essential mathematics constituents (shape, volume and net), and that evolved to the next conceptual model which was the establishing of relationships between essential variables to get the biggest box; the length of cut-out affecting the volume of the box.

Modelling Stage: Prediction

HA1

Revising "Final" Solution Model. The group predicted that the biggest volume was obtained when the length of the square cut-out was 8 cm. This prediction was put into doubt when the teacher-facilitator asked "*But can it be 8-point something?*" The group was exasperated at first when S1 exclaimed "*8.1, 8.2, 8.3...*" to show what she had understood from the teacher's question that they had to further explore decimal fractions of the lengths of the square

cut-outs to determine if they could get even bigger volumes. The group realised that it was possible to look deeper when S1 said “*We try 8.5 first*”. The provocation led to a re-analysis of their solution model towards finding a better fit based on the expectation of the task.

However, after finding the biggest volume from using decimal fractions, the group did not want to pursue further. They offered reasons based on the limitations in the physical measurement using the ruler.

S2: *But it is very hard to measure.*

T: *Yes, but have you all considered?*

S2: *Yeah, because the rule line does not have any smaller... (partitions).*

Nevertheless, their final model was a revision of the earlier version through factoring the use of decimal fractions.

HA2

Revising “Final” Solution Model. In a similar manner as HA1, the teacher-facilitator for HA2 provoked the group to think about optimising their solution model.

T: *And what makes you think that in the number system, you have only whole numbers? In the number system, other than whole numbers, what do we have?*

S5: *Decimals.*

T: *Decimals. Are those numbers workable? Will those numbers offer you the bigger numbers (volume)?*

The scaffolding enabled the students to scrutinise their solution further. As they tried using decimal fractions from the narrowed range of dimensions, they found that they obtained marginally bigger volumes. They finally predicted the dimensions 33.3 cm by 33.3 cm by 8.35 cm as their optimal combination that gave them the biggest volume.

When it came to predicting their solution models, both groups obtained their biggest volumes respectively via narrowing the dimensional ranges of the cut-outs until a point whereby the calculation for the volume was at a

maximum. Both groups had based their mathematical workings using integers. However, both groups had to have their thinking stretched by the teacher-facilitators who challenged them to think about using decimal fractions to determine if even larger volumes could be obtained. This scaffold enabled the groups to reanalyse their solutions and make revisions for improvement.

Both groups at this modelling stage were able to represent their models by way of a systematic list of dimensions to suggest how they had arrived at their solutions. In this respect, their justification was not made from wild guesses but from what they had worked through mathematically from previous stages and through several rounds of expressing, testing and revisions towards obtaining the biggest volume.

Modelling Stage: Optimisation

HA2

Enhanced Model. As the group had obtained 33.3cm by 33.3cm by 8.35cm as their “optimal” combination that gave them the biggest volume, they were then challenged by the teacher-facilitator to think about whether they could re-use those square cut-outs:

T: What if you don't sacrifice (the square cut-outs)? Everything counts?

That generated new ideas which brought the group back to re-analysing and improving their design. Eventually, as they were assisted by the teacher's promptings, S2 realised that they could increase the height of the box:

S2: ...use the spare parts to patch it up...Hey, can...You can cut one square into four then you paste on top.

This could be better explained by using the sequence of diagrams in Figure 3.

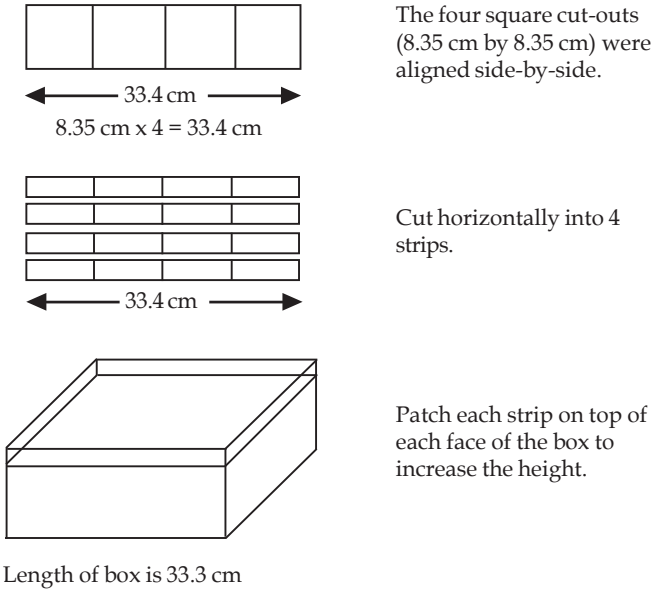

Figure 3. Enhancements made to get the biggest box.

Although from Figure 3, there was a difference of 0.1 cm between the length of the strip and the box, this was not deliberated upon by the group. In their building of the concrete artifact, the vanguard sheet was flimsy enough to make a box without much notice to the difference of 0.1cm. Even then, the 8.35 cm square cut-outs most probably were based on 8.3 cm or 8.4 cm since the ruler could not accommodate exact markings up to two decimal places.

For all the explorations carried out in the various modelling stages, the students had to come to a point where they needed to show that they had obtained a solution model they could justify as their optimal solution. HA1 had already declared that they were able to get the biggest volume through going into smaller partitions via decimal fractions. HA2 although worked along the same way as HA1 by considering the use of decimal fractions, they enhanced their artefact by making use of the cut-outs as patchworks to increase the height of the box. That convinced them that they had obtained the biggest volume.

Discussion

As a means to show how children's mathematical thinking can be made visible and as a contrast to traditional pedagogical approaches, I have situated the ideas of a modelling perspective into a PBL instructional setting. From the analyses of the two target groups with respect to their modelling process framed as modelling stages (*Description, Manipulation, Prediction and Optimisation*), evidence of their mathematizing and modelling were seen through the different mathematical interpretations elicited during the modelling process.

Although it was the first time both the groups experienced modelling activities, both groups showed that they were able to progress through the modelling stages successfully in that they were able to break down task details towards situating the problem, establish variable relationships and make connections between mathematics concepts, interpret their solutions in the light of task expectations, and justify their model solutions. During the modelling process, they were also seen to develop mathematical ideas which were used towards developing their final solution model. Their protocols showed the richness of their mathematical reasoning and as well, how they had applied their curricular mathematics knowledge into such complex problem-solving situations to construct conceptual models and then progressing towards a representational system such as a systematic list and a concrete artifact. In higher academic grades, this task could have been accomplished through calculus. For younger participants, it would be very good if they could in their exploration or prediction present a graph to show how a particular dimension in question was related to the volume of the box but this was not evident. Yet, what was heartening to see was that both groups adopted a systematic-listing approach to capture the combinations of dimensions and were able to narrow the range towards goal achievement. In HA1, it was interesting to note how two students argued over the conjecture that having a bigger base area and smaller height would give a bigger volume. Obviously if the height of the box was 0.1cm, it was mathematically workable to get a big volume, but practically, it was almost impossible to create that concrete artifact. In HA2, it was a motivating moment for the group when a student discovered a pattern of how the lengths of the square cut-outs were related to the height of the box that led to their systematic listing strategy.

The groups' progress through the modelling stages had been iterative with occasions where they had to revisit previous stages to clarify task details or re-analyse their designs. Such iterations augur well for the groups because they show how intense and persevering the groups were in trying to solve the problem. Such iterations also suggest the reality of what solving a problem means. Their mathematical interpretations also revealed that the students' reasoning was gaining firmer ground as they progressed into making conjectures, testing them and making generalisations.

The result of group collaboration was made evident during the absence of the teacher as they clarified ideas as well as challenged the efficacy of some ideas that were raised. There were plausible conjectures made and there were also misconceptions displayed through some "flawed" reasoning in the students' efforts to relate the variables and the physical appearance of the box. The "flawed" reasoning were exposed, challenged and clarified by the more knowledgeable others. Such monitoring behaviours promoted metacognitive awareness and monitoring of the problem-solving situation. It should also have enabled students to become more aware of their own reasoning when they expressed them or when they were questioned.

As students were easily satisfied whenever they had obtained an answer or a plausible solution, they tend to stop and think that that was the end of the problem-solving session. The presence of the teacher-facilitators changed that notion by enabling the students to think deeper. Both groups were challenged to re-analyse their solution models. They looked into decimal fractions and revised their solutions and justified why they should conclude with their newly derived dimensions and volumes. HA2 offered a creative aspect into the modelling of the box. They patched up the faces of the box to obtain an even greater height and thus a greater volume than before. Although this could not be possible had a graphing method be used as representation, it nevertheless could be seen as a combination of different "models" towards optimising the solution; the systematic listing as a set of interpretation of reasoning, and the patchwork as another set of interpretation of reasoning for enhancement. In a sense, the teacher-facilitators could be said to have enabled learning to take place in the students' zone of proximal development.

Limitations

The two target groups were from high-ability classes. Although two groups from the mixed-ability classes had also been video-recorded on their modeling endeavour of the same task, it was unfortunate that both recordings experienced problems. One was due to equipment failure, and the other was because the other non-target groups were too near the target group, hence the noise generated by the other groups overwhelmed the conversations of the target group. It would have been interesting to determine how the mixed-ability groups had managed the modelling situations.

Implications and Issues

The findings and discussion all point to a pedagogy that is vastly different from traditional problem solving. The different mathematical interpretations elicited during mathematical modelling reveal important aspects about the mathematical objects, relations, operations, and patterns underlying the students' thinking. It also shows that children can model via systems of representations although their thinking and outputs might be at different levels of sophistication, a finding consistent with other related research stemming from a modelling perspective (Lesh & Doerr, 2000). Important mathematical knowledge and ideas are elicited, for example, the students' abilities to interpret, analyse, explain, hypothesize, conjecture, compare, and justify.

Mathematical modelling as problem solving from a modelling perspective does not insist that students get the correct answer. It has been acknowledged that students' initial conceptions developed during the modelling process could be characterised by unwarranted assumptions or the imposing of inappropriate constraints (English & Watters, 2004) and that their reasoning could also be seen as uncoordinated and naïve (Lesh & Doerr, 2000). The difficulties they encounter should not be viewed as being getting stuck but as opportunities for refining of initial ideas. As observed in the Biggest Box Problem, the various "flawed" reasoning that surfaced were not penalised but rather were appreciated because it exposed the students' misconceptions and it provided opportunities for others to debate those ideas. What was important was that through the modelling process the students were able to edge towards what they believed would lead to their model solution. In this sense, as contrasted with traditional problem solving, the modelling perspective sees that "the process is the product"

(Lesh & Doerr, 2003, p.3).

The use of a PBL platform serves important functions for mathematical modelling. It enables the interaction of its three important tenets; students, task, and teacher. Students were observed to question, critique, and justify their own and their peers' contributions. The teacher assisted in scaffolding towards extending the students' thinking. These interactions generated a discourse rich in mathematical and metacognitive thinking. Not only that, for students to work in groups to solve a single problem in approximately one hour suggests how their engagement has been developing their spirit of perseverance towards goal resolution which is starkly in contrast to the practice of solving 50 mathematics questions and word problems in about two hours under formal assessment conditions. Mathematical modelling as problem solving in a PBL setting also provides the opportunity for students to apply and transfer curricular mathematics knowledge into new and real-world settings.

Apart from the benefits of the modelling experiences that have been discussed, it has to be acknowledged that it would take a concerted effort by like-minded mathematics educators to educate school management, teachers, students and parents to gradually embrace this new pedagogy. Mathematics learning and problem solving viewed from a modelling perspective might probably be a very novel way to look at problem solving for most teachers and students who are steeped in solving structured word problems and where products matter more than the process. The unlearning and relearning as to what counts as mathematical problem solving and mathematical development in the reformed mathematics education landscape needs to be addressed if the intended Singapore Mathematics Curriculum Framework is to be enacted and actualised. Although the issues involved in embracing such constructivist paradigms may be complex and challenging, Vasan, Lesh and Bakar's (2007) perspective of Singapore's educational reforms asserted that a research process be put in place to build documentation and empirical evidence of such classroom practices so as to inform about the new ways of thinking about the nature of student development, teaching, learning and problem solving. That would require teachers to take the step of faith and function as facilitators and mediators, and students be engaged in a situated mode of learning in order to know what worked and what did not towards growing in understanding to become better problem solvers. They called for the need to investigate the ways of

thinking by designing thought-revealing artifacts through a series of iterative cycles as experts, researchers, teachers and students work in partnership in providing the documented trials towards shaping policies in curriculum content and pedagogy. Recent reviews by local researchers have been encouraging in that over the past 15 years, there have been more research carried out by teacher practitioners that covers alternative pedagogies (Foong, 2007; Fan & Zhu, 2007) although none was from a modelling perspective. However, whether these pedagogies continue after the research was carried out is an aspect that could not be ascertained. In this paper, I have presented my attempt in taking that step of faith to document and detail the mathematical development of children via a modelling perspective through classroom research. This Phase One study has also paved the way for the Phase Two study which would see a new cohort of Primary 6 students undertaking a series of five modelling tasks in an attempt to investigate their modelling process.

Conclusion

The revision to the *Process* component of the SMCF suggests a more communicative and constructive approach in developing mathematical thinking. Mathematics learning has to take into consideration real-world situations, and modelling activities are seen as the catalyst to promoting mathematical reasoning and making the learning meaningful. Mathematical modelling from a modelling perspective looks promising when situated in a PBL setting with respect to providing pupils with opportunities to develop mathematical processes that traditional problem solving approaches would not. Because it holds promise in significantly impacting mathematical thinking and development, there is potential that when appropriately enacted in the curriculum, it could enable students to experience problem solving more meaningfully and for teachers as well to collaborate with students and assess how students apply their curricular knowledge in new problem-based settings. There is a greater need for research to increasingly investigate ideas and concept development in the light of using model-eliciting tasks, and in particular, how the aspects of metacognition, motivation, social interaction, and teacher scaffolding help in the pupils' mathematical development.

References

- Chan, C. M. E. (2008). Mathematical modelling experiences for mathematical development in children. *Thinking Classroom*, 9(2), 37-45.
- Chi, M. T. H. (1997). Quantifying qualitative analyses of verbal data: A practical guide. *The Journal of the Learning Sciences*, 6(3), 271-315.
- De Lange, J. (2001). Mathematics for literacy. *Proceedings of the National Forum on Quantitative Literacy held at the National Academy of Sciences in Washington, D.C. on December 1-2, 2001*.
- English, L. D. (2003). Mathematical modelling with young learners. In S. J. Lamon, W. A. Parker, & K. Houston (Eds.), *Mathematical modelling: A way of Life – ICTMA 11* (pp. 3-18). Horwood Publishing Limited.
- English, L. D., & Watters, J. J. (2004). Mathematical modelling with young children. In M. J. Hoines & A. B. Fuglestad (Eds.), *Proceedings of the 28th annual conference of the International Group for the Psychology of Mathematics Education* (Vol. 2, pp. 335-342). Bergen, Norway: PME.
- English, L. D., & Watters, J. J. (2005). Mathematical modelling in third-grade classrooms. *Mathematics Education Research Journal*, 16(3), 59-80.
- English, L. D. (2006). Mathematical modelling in the primary school: Children's construction of a consumer guide. *Educational Studies in Mathematics*, 62(3), 303-323.
- Fan, L., & Zhu, Y. (2007). From convergence to divergence: The development of mathematical problem solving research, curriculum, and classroom practice in Singapore. *ZDM*, 39(5-6), 491-501.
- Foong, P. Y. (2007). Teacher as researcher: a review on mathematics education research of Singapore teachers. *The Mathematics Educator*, 10(1), 3-20.
- Fravillig, J. (2001). Strategies for advancing children's mathematical thinking. *Teaching Children Mathematics*, 7, 454-459.
- Lehrer, R., & Schauble, L. (2000). Inventing data structures for representational purposes: Elementary grade students' classification models. *Mathematical Thinking and Learning*, 2(1&2), 49-72.
- Lehrer, R., & Schauble, L. (2003). Origins and evolution of model-based reasoning in mathematics and science. In R.A. Lesh & H. M. Doerr (Eds.), *Beyond constructivism: Models and modeling perspectives on mathematics problem solving, learning and teaching* (pp. 59-70). Mahwah, NJ: Lawrence Erlbaum Associates.

- Lesh, R., Cramer, K., Doerr, H. M., Post, T., & Zawojewski, J. S. (2003). Model development sequences. In R. Lesh & H. M. Doerr (Eds.), *Beyond constructivism: Models and modeling perspectives on mathematics problem solving, learning and teaching* (pp. 35-58). Mahwah, NJ: Lawrence Erlbaum Associates.
- Lesh, R., & Doerr, H. M. (2000). Symbolizing, communicating, and mathematizing: Key components of models and modeling. In P. Cobb, E. Yackel, and K. McCain (Eds.), *Symbolizing and communication in mathematics classrooms: Perspectives on discourse, tools, and instructional design* (pp. 381-284). Mahwah, NJ: Lawrence Erlbaum Associates.
- Lesh, R., & Doerr, H. M. (2003). Foundations of a models and modeling perspective in mathematics teaching and learning. In R.A. Lesh & H. M. Doerr (Eds.), *Beyond constructivism: Models and modeling perspectives on mathematics problem solving, learning and teaching* (pp. 3-34). Mahwah, NJ: Lawrence Erlbaum Associates.
- Lesh, R. A., & Sriraman, B. (2005). John Dewey revisited – pragmatism and the models-modeling perspective on mathematical learning. In A. Beckmann, C. Michelsen, & B. Sriraman (Eds.). *Proceedings of the 1st international symposium of mathematics and its connections to the arts and sciences* (pp. 7-31). The University of Education, Schwöbisch Gmund, Germany.
- Lesh, R., & Zawojewski, J. (2007). Problem solving and modeling. In F. K. Lester (Ed.), *Second handbook of research on mathematics teaching and learning: A project of the National Council of Teachers of Mathematics* (pp. 763-803). Charlotte, NC: Image Age Publishing.
- Ministry of Education. (2001). *Mathematics Syllabus - Primary*, Singapore: Curriculum Planning and Developmental Division.
- Ministry of Education. (2007). *Mathematics Syllabus - Primary*, Singapore: Curriculum Planning and Developmental Division.
- Mousoulides, N., Sriraman, B., & Christou, C. (2007). From problem solving to modelling: The emergence of models and modelling perspectives. *Nordic Studies in Mathematics Education*, 12(1), 23-47.
- Tan, O. S. (2003). *Problem-based learning innovation: Using problems to power learning in the 21st century*. Singapore: Thomson Learning.
- Uden, L., & Beaumont, C. (2006). *Technology and problem-based learning*. Hershey, PA: Information Science Publishing.

- Vasan, M. L., Lesh, R., & Bakar, M. A., (2007). Beyond efficiency: A critical perspective of Singapore's educational reforms. In R. A. Lesh, E. Hamilton, & J. J. Kaput (Eds.), *Foundations for the future in mathematics education* (pp. 301-313). Mahwah, NJ: Lawrence Erlbaum Associates.
- Yoon, C., & Thompson, M. (2007). Cultivating modeling abilities. In R. A. Lesh, E. Hamilton, & J. J. Kaput (Eds.), *Foundations for the future in mathematics education* (pp. 201-209). Mahwah, NJ: Lawrence Erlbaum Associates.

Author:

Chan Chun Ming Eric, National Institute of Education, Nanyang Technological University, Singapore ; e-mail: eric.chan@nie.edu.sg